

ArgoMoon Propulsion System

VACCO's hybrid Micro Propulsion System (MiPS) combines green mono-propellant and cold gas propulsion in a single system to provide attitude control and orbital maneuvering. Argotec's ArgoMoon program utilizes VACCO's hybrid propulsion system to achieve high levels of total impulse in a limited volume to accomplish the mission requirements.

Performance density: 692 N-sec/L

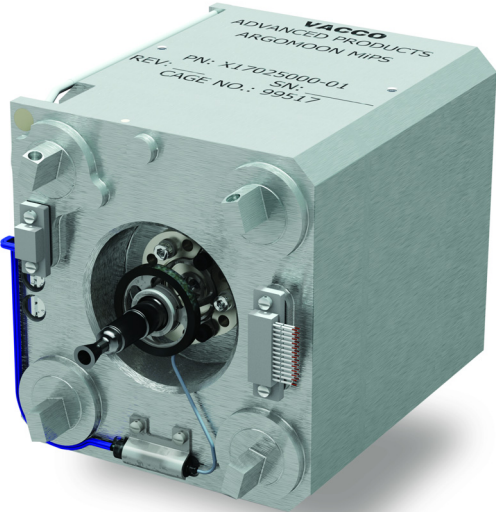

The VACCO ArgoMoon MiPS is approximately 1.3U plus the tuna can volume and uses one 100 mN green thruster to develop 783 N-sec of total impulse that provides 56 m/s of delta-V for a 14 kg CubeSat. The four 25 mN cold gas thrusters develop 72 N-sec of total impulse. Each thruster independently operates to perform both delta-V and ACS maneuvers through an integrated microprocessor controller.

Features

- Integral titanium fluid control manifold and low friction, space grade valves
- All welded tank construction contains 420 g of propellant and 215 g of pressurant
- Integrated microcontroller and RS-422 interface enable high-level commands from the host spacecraft
- Low power with < 1 Watt for health and status monitoring
- Easily configured for different mono-propellants
 - ADN green (LMP-103S)
 - Air Force green (AF-M315E)
- Performance density: 692 N-sec/L

Operating Parameters

Propellant.....LMP-103S & R134a	Total Impulse @10°C.....72 & 783 N-s
MDP.....16.8 Bar (244 psia)	Dry Mass.....1.430 kg Max
Proof Pressure.....25.2 Bar (366 psia)	Wet Mass 95% Fill @ 10°C.....2.065 kg Max
Burst Pressure.....42.1 Bar (610 psia)	Operating Voltage For Telemetry.....9.0-12.6 V _{DC}
Internal Leakage BOL.....<1X10 ⁻⁴ sccs GHe	Operating Voltage For Heaters & Valves.....9.0-12.6 V _{DC}
Internal Leakage EOL.....<1.0 x10 ⁻³ sccs GHe	Standby Power.....1 W Max
External Leakage.....<1.0 x 10 ⁻⁶ sccs GHe	Warmup Power.....20 W Max
Operating Temp.....10°C to 40°C	Thruster Operating Power4.3 W Max
Non-Operating Temp.....-34°C to 60°C	Data Interface.....RS-422

Performance characteristics are based on customer requirements. As such, they are not representative of component capabilities or limitations.



Envelope Drawing

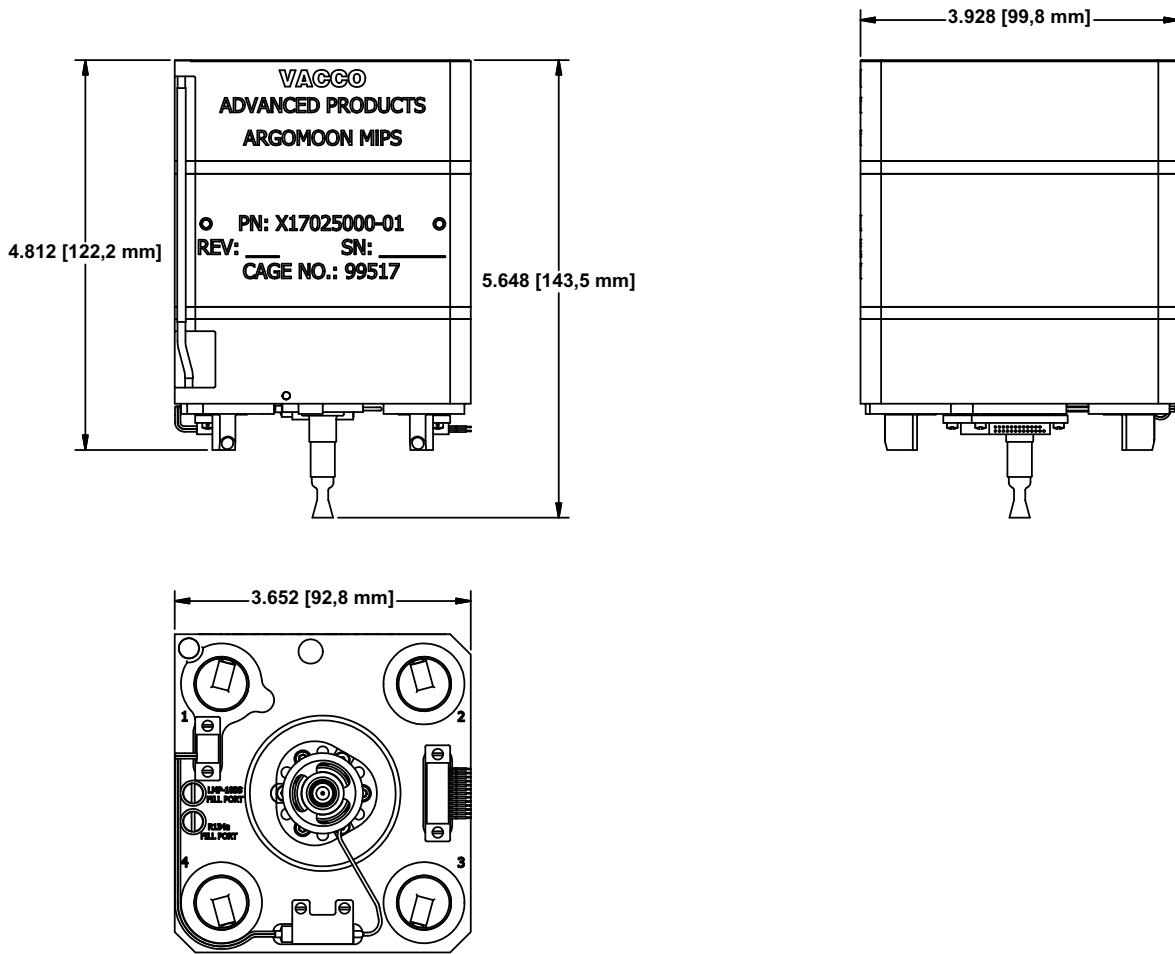

Flow Schematic

